

TITLE 10G SR SFP+ Transceiver	DOC No.	DTRX-000004
	REVISION : 02	AUTHORIZED BY : Mike Sun
	DATE : 2020.05.25	CLASSIFICATION : Optical Transceiver

1. SCOPE

The scope of this specification is the definition of a high performance, cost effective modules, which is optimized for 10G SR SFP+, and transmission distance up to 300m. The transceiver consists of two sections: The transmitter section incorporates a 850nm VCSEL. The receiver section consists of a PIN photodiode integrated with a transimpedance preamplifier (TIA).

2. PRODUCT DESCRIPTION

2.1 PRODUCT NAME AND SERIES NUMBER(S)

10G SR SFP+ Transceiver

Part Number	Data Rate	Wavelength (nm)	Distance	Media	Power (dBm)	Sen. (dBm)	Connector	Tem.
P58000BCCA01-1	10G	850	300m	MMF	-8.2 ~ 1	-11.1	LC	C

TITLE 10G SR SFP+ Transceiver	DOC No.	DTRX-000004
	REVISION : 02	AUTHORIZED BY : Mike Sun
	DATE : 2020.05.25	CLASSIFICATION : Optical Transceiver

2.2 DIMENSIONS, MATERIALS, PLATINGS AND MARKING

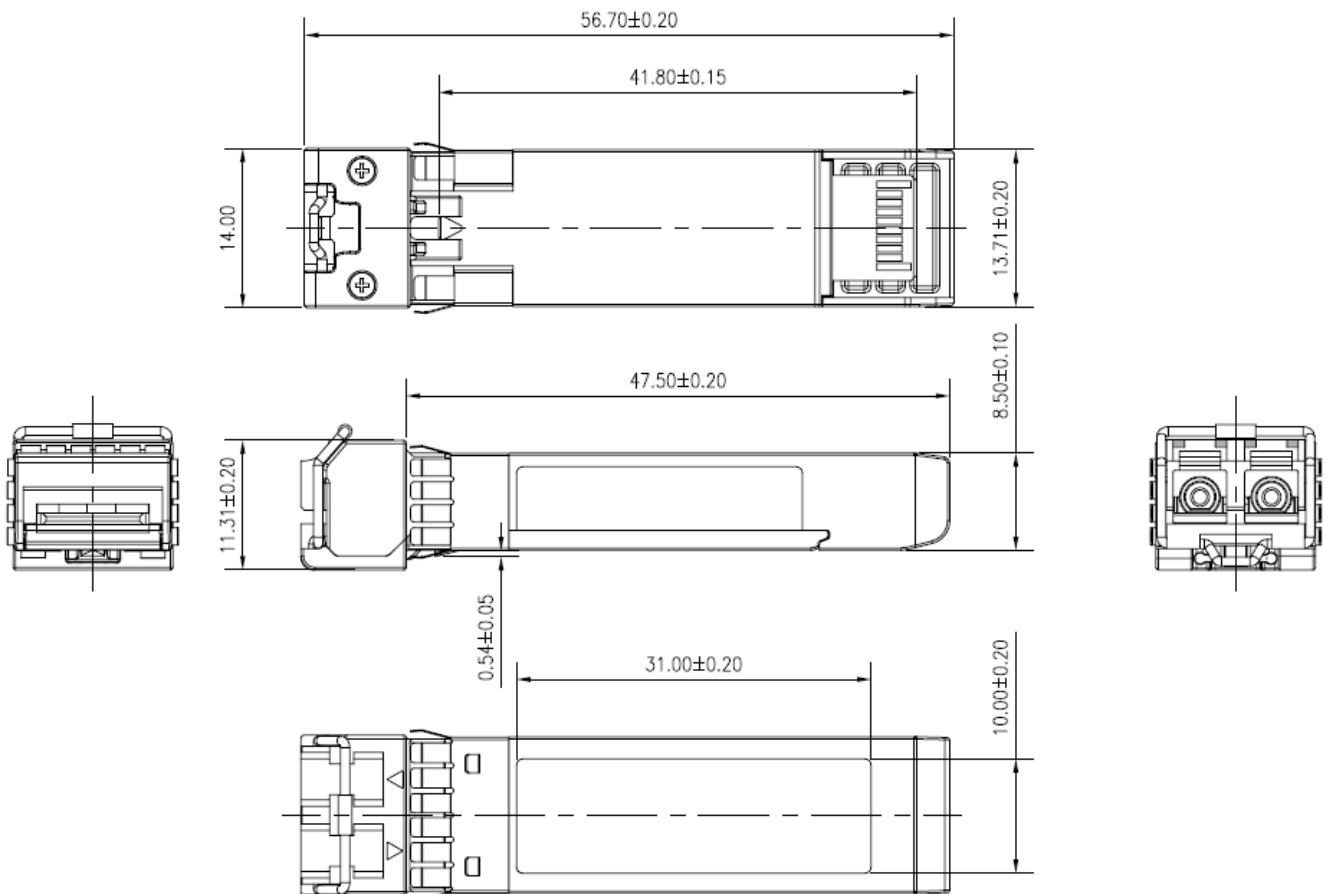

Unit is millimeter. All dimensions are ± 0.1 mm unless otherwise specified.

3. APPLICABLE DOCUMENTS AND SPECIFICATIONS

- Compliant with SFP+ MSA
- 10Gbps IEEE 802.3ae
- 10GBASE-SR and 10GBASE-SW compliant
- Compliant with FC-PI-4 V8.0

4. QUALIFICATION

TITLE 10G SR SFP+ Transceiver	DOC No.	DTRX-000004
	REVISION : 02	AUTHORIZED BY : Mike Sun
	DATE : 2020.05.25	CLASSIFICATION : Optical Transceiver

- Electrostatic Discharge (ESD) to the Electrical Pins
- Electrostatic Discharge (ESD) to the LC Connector
- RoHS compliance

5. Absolute Maximum Ratings & Recommended Operating Conditions

Absolute Maximum Ratings				
Parameter	Symbol	Min.	Max.	Unit
Storage Temperature	TS	-40	+85	°C
Supply Voltage	VCC3	0	3.6	V
Relative Humidity(Non-condensing)	RH	0	85	%
RX Input Average Power	Pmax	-	0	dBm

Recommended Operating Conditions					
Parameter	Symbol	Min.	Typical	Max.	Unit
Operating Case Temperature	TC	0	25	70	°C
Power Supply Voltage	VCC3	3.135	3.3	3.465	V
	ICC3			300	mA
Power Dissipation	P _D			1	W
Data Rate		1	10.3125		Gbps
Transmission Distance	OM3			300	m

Transmitter Operating Characteristic-Optical, Electrical

JESS-LINK PRODUCTS CO., LTD
PRODUCT SPECIFICATION

TITLE 10G SR SFP+ Transceiver	DOC No.	DTRX-000004
	REVISION : 02	AUTHORIZED BY : Mike Sun
	DATE : 2020.05.25	CLASSIFICATION : Optical Transceiver

Parameter	Symbol	Min.	Typical	Max.	Unit	Note
Center Wavelength	λ_c	840	850	860	nm	Note1
Laser Off Power	Poff	-	-	-30	dBm	
Average Optical Power	Pavg	-8.2	-	-1	dBm	For 10.3G
Optical modulation amplitude	OMA	-4.3			dBm	For 10.3G
RMS spectral width				0.45	nm	
Extinction Ratio	ER	3	-	-	dB	For 10.3G
Transmitter Dispersion Penalty	TDP	-	-	3.9	dB	
Relative Intensity Noise	RIN	-	-	-128	dB/Hz	
Operating Data Rate		1	10.3125		Gbps	
Optical Eye Mask Margin		5			%	
Tx Input Diff Swing	VI	180		1200	mV	
Tx_Disable	Disable	2		VCC	V	
	Enable	VEE		VEE+0.8	V	

Notes:

1. Average optical power shall be measured using the methods specified in TIA/EIA-455-95.

Receiver Operating Characteristic-Optical, Electrical

Parameter	Symbol	Min.	Typ.	Max.	Unit	Note
Center Wavelength	λ	840	850	860	nm	
Receiver Sensitivity (OMA)			-14	-11.1	dBm	1
LOS Assert	LOS A	-30		-	dBm	
LOS Dessert	LOS D			-14	dBm	For 10.3G
LOS Hysteresis	LOSH	0.5		-	dB	
Overload	Pin	0			dBm	

TITLE 10G SR SFP+ Transceiver	DOC No.	DTRX-000004
	REVISION : 02	AUTHORIZED BY : Mike Sun
	DATE : 2020.05.25	CLASSIFICATION : Optical Transceiver

Return Loss of Receiver		12			dB	
Operating Data Rate		1	10.3125		Gbps	
Rx Output Diff Swing	Vo	370		850	mV	
Rx Output Rise and Fall Time	Tr/Tf		60		ps	20% to 80%

Notes:

1. Receiver sensitivity is informative. shall be measured with conformance test signal for BER = 1×10^{-12} .

Control and Status I/O Timing Characteristics

Parameter	Symbol	Min.	Max.	Unit	Note
TX Disable Assert Time	t_off		100	μs	Note1
TX Disable Negate Time	t_on		2	ms	Note2
Time to initialize including reset of TX_Fault	t_init		300	ms	Note3
TX Fault Assert Time	t_fault		1	ms	Note4
Tx_Fault Reset	t_reset	10		μs	Note5
LOS Assert Time	t_loss_on		100	μs	Note6
LOS Deassert Time	t_loss_off		100	μs	Note7
Serial ID Clock Rate	f_serial_clock	100	400	kHz	

Notes:

1. Time from rising edge of TX Disable to when the optical output falls below 10% of nominal
2. Time from falling edge of TX Disable to when the modulated optical output rises above 90% of nominal
3. From power on or negation of TX Fault using TX Disable
4. Time from fault to TX fault on
5. Time TX Disable must be held high to reset TX_fault
6. Time from LOS state to RX LOS assert
7. Time from non-LOS state to RX LOS deassert.

6. Applications Note :

TITLE 10G SR SFP+ Transceiver	DOC No.	DTRX-000004
	REVISION : 02	AUTHORIZED BY : Mike Sun
	DATE : 2020.05.25	CLASSIFICATION : Optical Transceiver

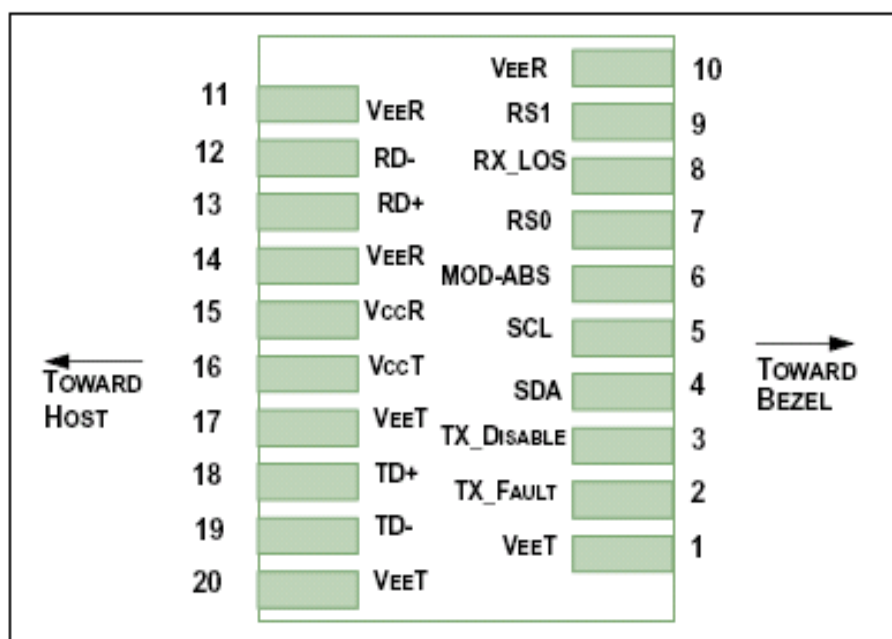

Pin Definitions

Pin Assignment

Pin	Logic	Symbol	Name/Description	Note
1		VeeT	Module Transmitter Ground	Note1
2	LVTTL-O	TX_Fault	Module Transmitter Fault	Note2
3	LVTTL-I	TX_Disable	Transmitter Disable; Turns off transmitter laser output	Note3
4	LVTTL-I/O	SDA	2-wire Serial Interface Data Line (Same as MOD-DEF2 as defined in the INF-8074i)	Note4
5	LVTTL-I/O	SCL	2-wire Serial Interface Clock (Same as MOD-DEF1 as defined in the INF-8074i)	Note4
6		MOD_ABS	Module Absent, connected to VeeT or VeeR in the module	Note5
7	LVTTL-I	RS0	Rate Select 0, optionally controls SFP+ module receiver. When High input data rate 10.3GBd and when LOW input data rate 1.25GBd.	
8	LVTTL-O	RX_LOS	Receiver Loss of Signal Indication (In FC designated as RX_LOS, in SONET designated as LOS, and in Ethernet designated at Signal Detect)	Note2

JESS-LINK PRODUCTS CO., LTD
PRODUCT SPECIFICATION

TITLE 10G SR SFP+ Transceiver	DOC No.	DTRX-000004
	REVISION : 02	AUTHORIZED BY : Mike Sun
	DATE : 2020.05.25	CLASSIFICATION : Optical Transceiver

9	LVTTTL-I	RS1	Rate Select 1, optionally controls SFP+ transmitter. When High input data rate 10.3GBd and when LOW input data rate 1.25 GBd.	
10		VeeR	Module Receiver Ground	Note1
11		VeeR	Module Receiver Ground	Note1
12	CML-O	RD-	Receiver Inverted Data Output	
13	CML-O	RD+	Receiver Non-Inverted Data Output	
14		VeeR	Module Receiver Ground	Note1
15		VccR	Module Receiver 3.3 V Supply	
16		VccT	Module Transmitter 3.3 V Supply	
17		VeeT	Module Transmitter Ground	Note1
18	CML-I	TD+	Transmitter Non-Inverted Data Input	
19	CML-I	TD-	Transmitter Inverted Data Input	
20		VeeT	Module Transmitter Ground	Note1

Notes:

1. The module signal ground pins, VeeR and VeeT, shall be isolated from the module case.
2. This pin is an open collector/drain output pin and shall be pulled up with 4.7k-10kohms to Host_Vcc on the host board. Pull ups can be connected to multiple power supplies, however the host board design shall ensure that no module pin has voltage exceeding module VccT/R + 0.5 V.
3. This pin is an open collector/drain input pin and shall be pulled up with 4.7k-10kohms to VccT in the module.
4. See [sff-8431 4.2 2-wire Electrical Specifications](#) .
5. This pin shall be pulled up with 4.7k-10kohms to Host_Vcc on the host board.

TITLE 10G SR SFP+ Transceiver	DOC No.	DTRX-000004
	REVISION : 02	AUTHORIZED BY : Mike Sun
	DATE : 2020.05.25	CLASSIFICATION : Optical Transceiver

Receiver Section

The receiver converts 10.3125Gbit/s serial optical data into serial PECL/CML electrical data. An open collector compatible Loss of Signal is provided. Rx_LOS when high indicates an optical signal level below that specified in the relevant standard. The Rx_LOS contact is an open drain/collector output and shall be pulled up to Vcc_Host in the host with a resistor in the range 4.7-10 kΩ, or with an active termination. Power supply filtering is recommended for both the transmitter and receiver. The Rx_LOS signal is intended as a preliminary indication to the system in which the SFP+ is installed that the received signal strength is below the specified range. Such an indication typically points to non-installed cables, broken cables, or a disabled, failing or a powered off transmitter at the far end of the cable.

Recommended Interface Circuit

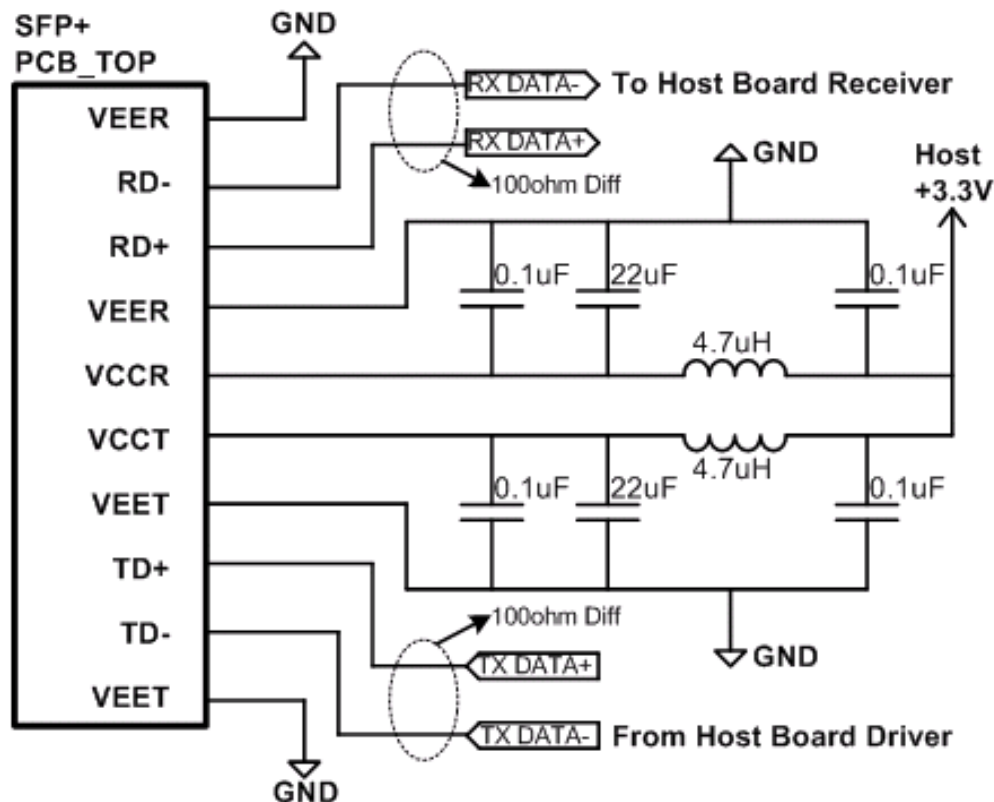
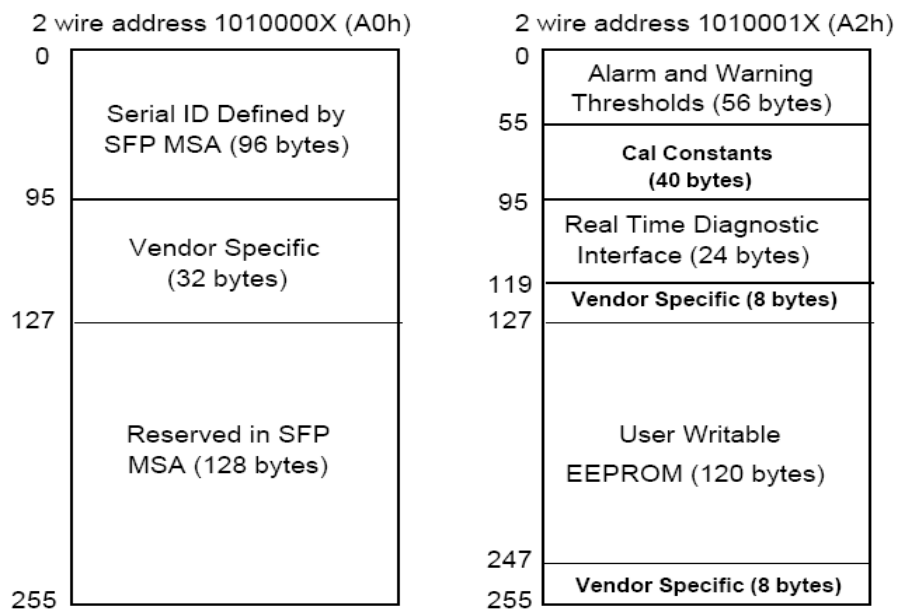

Figure3

TITLE 10G SR SFP+ Transceiver	DOC No.	DTRX-000004
	REVISION : 02	AUTHORIZED BY : Mike Sun
	DATE : 2020.05.25	CLASSIFICATION : Optical Transceiver

Digital Diagnostic Memory Map



8. Modification History

Rev.	Comments	Date	Originator	Approval
01	Preliminary Draft	2016.08.05	Mike Sun	Ray Yang
02	Revised Section 2.2	2020.05.25	Mike Sun	Ray Yang